

Thank you very much for choosing a Noctua cooler for your Intel Xeon system. Please install the cooler according to this manual.

Should you encounter any difficulties, please check the FAQs on our website and don't hesitate to contact our support team at support@noctua.at. Noctua cannot be held responsible for any damage or losses caused by compatibility issues.

Please note that a CEK spring should be used on the rear side of the socket when installing the cooler. These springs are usually supplied by the mainboard manufacturer.

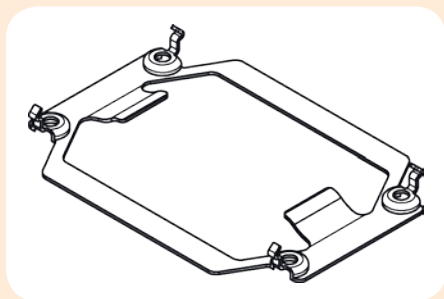

If you're replacing a standard Intel cooler, the CEK spring has most likely already been installed.

If your system doesn't have a CEK spring or you didn't get one with your mainboard, please contact our support team in order to obtain one.

Required mounting parts:

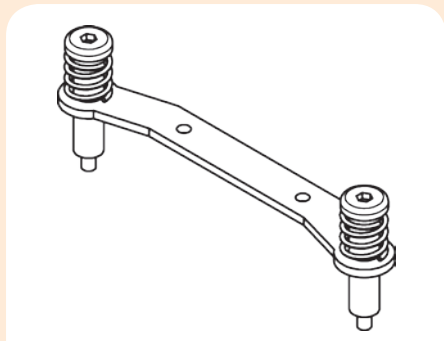

2x fastening brackets (pre-installed to the cooler)

- 1x NT-H1 thermal compound
- 4x Anti-Vibration-Stripes
- 1x NF-B9 92mm fan
- 4x Fan clips

Step 1: Applying thermal paste

If there are residual traces of thermal paste or thermal pads on your CPU, please clean them off first. Press a small drop (4-5mm diameter) of NT-H1 onto the centre of the heat-spreader.

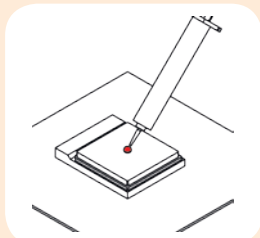

Caution: Applying too much thermal paste will lower the heat conductivity and cooling performance!

Step 2: Attaching the heatsink to the CPU

Take off the protection cover at the bottom side of the heat-sink first. Then put the cooler onto the CPU and tighten the four spring-loaded screws until they stop using the supplied screwdriver.

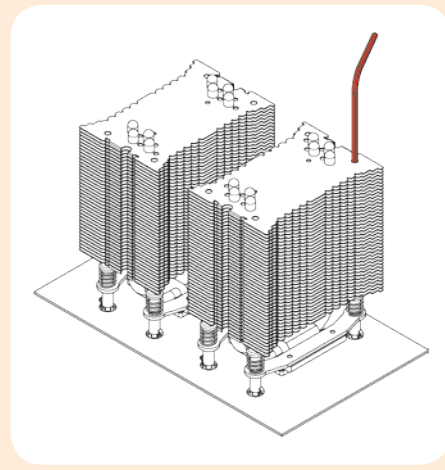

On Dual Xeon setups, please install the coolers with the narrow parts of the fin stacks facing each other (as shown below), so that you can put a fan in between in order to create an air duct.

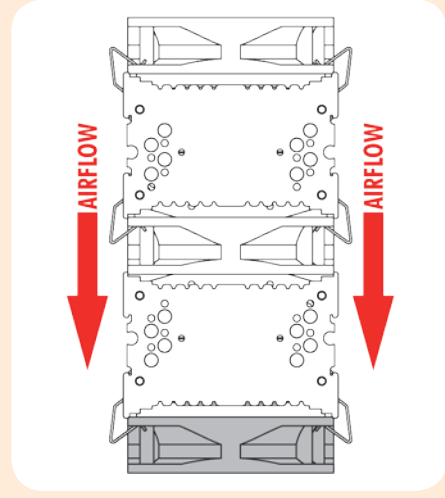

Please note that a third fan can be installed in order to further improve cooling performance. This fan has to be purchased separately though.

Step 3: Attaching the fan

First stick the 2 anti-vibration strips onto the cooling fins in order to dampen minor vibrations emitted by the fan.

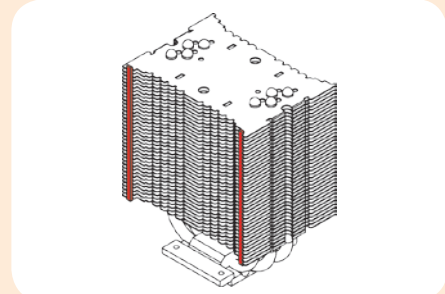

Then attach the fan to the heatsink using the 2 steel clips, placing it so that it blows onto the heatsink (You can optionally use the second pair of clips to install a second fan).

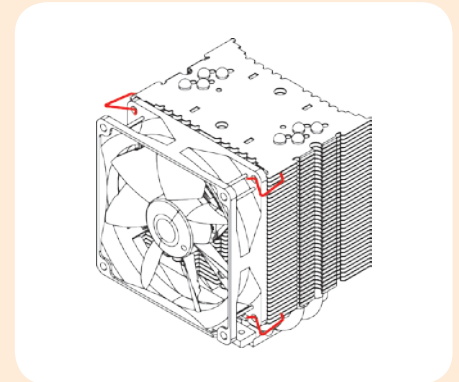
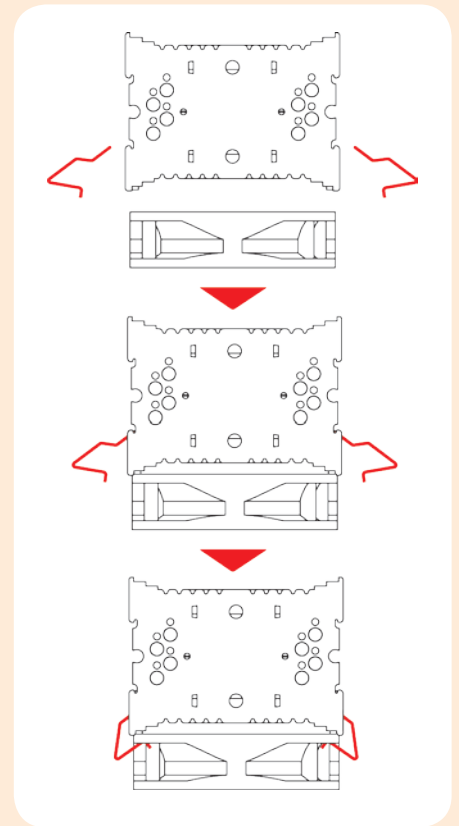

Connect the fan to the mainboard, power supply or fan controller. Depending on your CPU and the temperature inside the case, you may interconnect the supplied Low-Noise Adapter (L.N.A.) or Ultra-Low-Noise Adapter (U.L.N.A.) in order to further reduce the fan's operating noise.

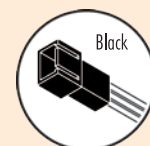

Low-Noise Adapter (L.N.A.)
1300 RPM, 13.1 dB(A)

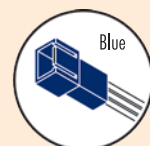

Ultra-Low-Noise Adapter (U.L.N.A.)
1000 RPM, 7.9 dB(A)

Caution: When using the (U.)L.N.A., check the temperature of your CPU using appropriate software (e.g. the respective applications of your mainboard manufacturer), in order to evade automatic throttling of the CPU due to the increased temperature. If the cooling performance is insufficient, please increase case ventilation or remove the (U.)L.N.A.