

# NM-AM4-L9aL9i

## NM-AM4-L9aL9i NOCTUA MOUNTING KIT



Continuing Noctua's tradition of supplying customers with its premium-class SecuFirm2™ mountings free of charge, the NM-AM4-L9aL9i kit allows Noctua users to upgrade NH-L9a and NH-L9i coolers to AMD's AM4 socket (Ryzen). It is a dedicated solution for the NH-L9a and NH-L9i models and has been designed to combine outstanding reliability, optimal contact pressure and easy, straightforward installation. Bringing the trusted SecuFirm2™ quality to AMD's AM4 platform, the NM-AM4-L9aL9i is an enthusiast-grade mounting kit that meets the highest demands in safety, performance and ease of use.

### Trusted SecuFirm2™ Quality

Over the years, SecuFirm2™ has become synonymous with impeccable long-term stability and flawless craftsmanship. Enthusiast users and industry clients alike trust the time-tested quality of Noctua's professional mounting systems.

### Tailor-made for AM4

In order to cut costs, many manufacturers use cross-platform parts for both Intel and AMD, which can cause compatibility issues. Noctua's SecuFirm2™ mounting system for AM4 has been tailor-made for this socket in order to ensure optimal compatibility.

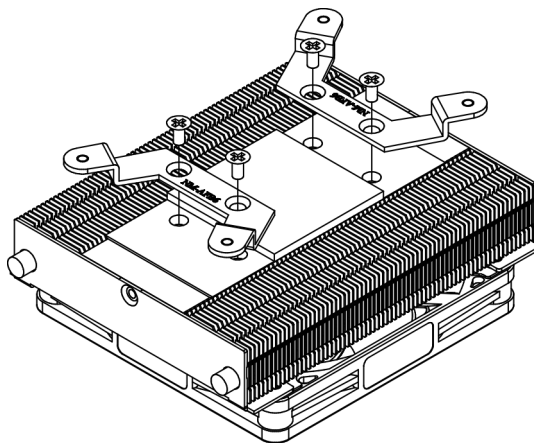

### Socket - & Cooler - compatibility

Socket compatibility	AM4
Free upgrade	NH-L9a, NH-L9i
Incompatible (please choose the NM-AM4 kit for these models)	NH-C12P, NH-C12P SE14, NH-C14, NH-C14S, NH-D14, NH-D14 SE2011, NH-D15, NH-D15S, NH-D9L, NH-L12, NH-L9x65, NH-U12, NH-U12F, NH-U12P, NH-U12P SE1366, NH-U12P SE2, NH-U9, NH-U9B, NH-U9B SE2, NH-U9F, NH-U12DX, NH-U12DX 1366, NH-12DX i4, NH-U9DX i4, NH-U9DX 1366, NH-U12DO, NH-U9DO
Incompatible (please choose the NM-AM4 kit for these models)	NH-U14S, NH-U12S, NH-U9S
Incompatible (no kits available for these models)	NH-U12DO A3, NH-U9DO A3

*Caution: The NM-AM4-L9aL9i kit is compatible with the NH-L9a & NH-L9i only (please choose the NM-AM4-UxS kit for the NH-U14S, NH-U12S and NH-U9 and the NM-AM4 kit for all other models). Owners of the NH-L9a & NH-L9i can obtain the NM-AM4-L9aL9i mounting-kit free of charge. Proofs of purchase (photo, scan or screenshot of the invoice) of both an NH-L9a/NH-L9i cooler and either a socket AM4 motherboard or socket AM4 CPU are required.*

*The NH-L9i has been designed for the Intel LGA115x platform. While it can be installed without any problems on most AM4 motherboards using the NM-AM4-L9aL9i kit, it is possible that it may not fit in some cases. Therefore, please be extra careful when installing the NH-L9i on AM4 and verify that the cooler doesn't press against any other components. Please also see this FAQ for details.*

*The NM-AM4-L9aL9i SecuFirm2™ mounting-kit is also available for purchase at some of our resellers. If you need the kit urgently, please consider ordering it via a local reseller.*

### LOGISTICAL DATA

Product name	Noctua NM-AM4-L9aL9i
EAN-No.	901001820037-9
UPC-No.	84150112037-4
Dimensions (HxWxD)	150 x 115 x 30 mm
Weight	244 gr
Warranty	6 Years
MSPR	7.95 USD
Packaging unit	60 Pcs.
Dimensions / Unit (HxWxD)	370 x 310 x 325 mm
Weight / Unit	15.50 kg

### SCOPE OF DELIVERY

1x NM-ABP4 backplate
2x NM-AFB6 fastening brackets
4x NM-ABT1 mounting screws