

Thank you very much for choosing a Noctua cooler for your socket 1366 system.

The SecuFirm2™ Mounting-Kit for socket 1366 is compatible with the following CPU coolers: NH-C12P, NH-U12F, NH-U12P, NH-U9B, NH-U9F, NH-U12, NH-U9.

This manual will guide you through the installation process step by step using an NH-U12P heatsink as an example. Please note that the installation procedure is identical for all models.

Should you encounter any difficulties, please check the FAQs on our website and don't hesitate to contact our support team at support@noctua.at.

Noctua cannot be held responsible for any damage or losses caused by compatibility issues.

Multilingual versions of this manual are available on our website: www.noctua.at

Required mounting parts:

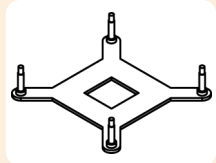

1x socket 1366 backplate

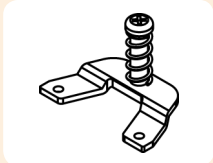

2x fastening brackets

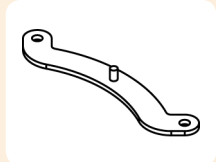

2x mounting bars

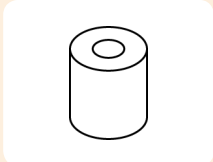

4x plastic spacers

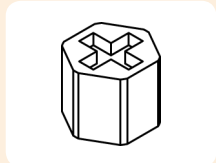

4x thumbscrews

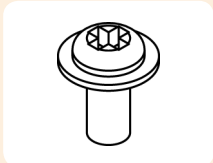

4x short screws

Step 1: Removing the mainboard

In case you want to use the cooler on an assembled system, you first have to remove the mainboard from the case as the cooler has to be screwed to the backplate on the back of the mainboard.

Step 2: Attaching the backplate

Place the backplate on the back side of the mainboard so that the screw threads stick through the mounting holes.

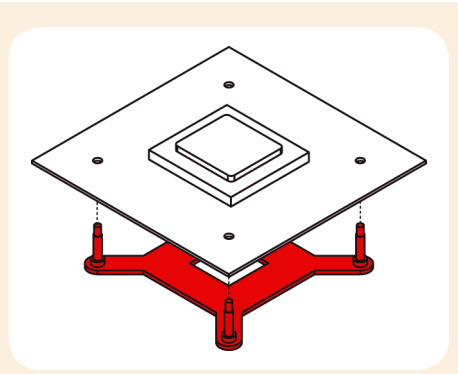

Step 3: Installing the mounting bars

First put the spacers onto the screw sockets of the backplate. Then fix the mounting bars using the 4 thumb screws.

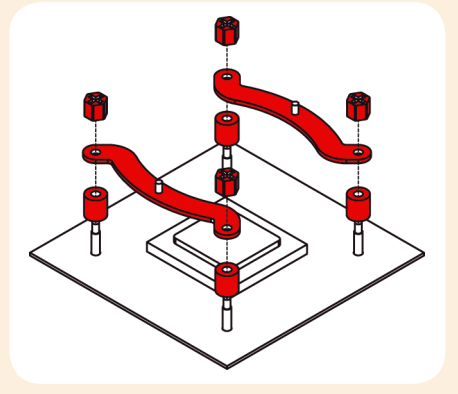

Choose the alignment of the mounting bars according to the desired final orientation of the cooler:

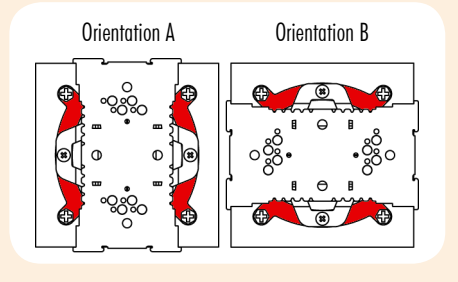

Caution: Make sure that the curved sides of the mounting bars are pointing outwards.

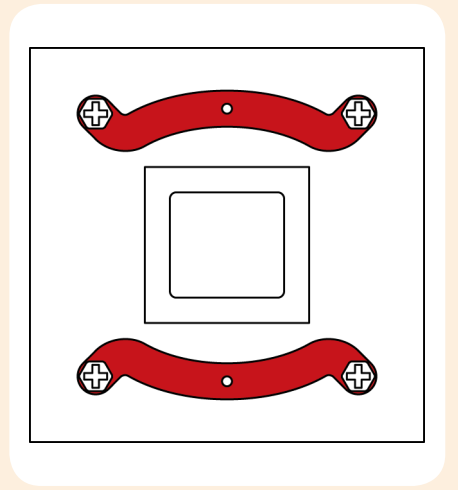

Step 4: Attaching the fastening brackets to the heatsink

Tightly screw the fastening brackets to the base of the heatsink using 4 short screws.

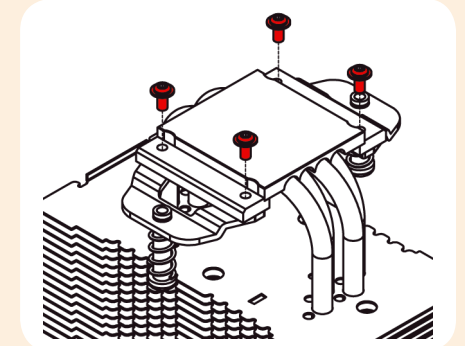

Step 5: Applying thermal paste

If there are residual traces of thermal paste or thermal pads on your CPU, please clean them off first. Then press a small drop (4-5mm diameter) of NT-H1 onto the centre of the heat-spreader.

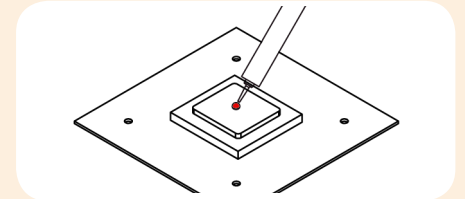

Caution: Applying too much thermal paste will lower the heat conductivity and cooling performance!

Step 6: Fastening the heatsink to the CPU

Caution: If you are using the cooler for the first time, please take off the protection cover at the bottom side of the heatsink first!

Put the heatsink onto the CPU and screw it to the screw threads of the mounting bars.

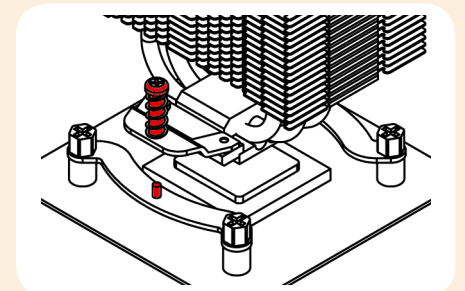

Caution: Tighten the screws until they stop.

Step 7: Installing the fan

Install the fan as described in the manual that came with the cooler.