



## ! LGA1700, LGA1200 & LGA115x

Dear customer,

Congratulations on choosing the Noctua NH-L12 Ghost S1 Edition.

Our classic NH-L12 has proven to be the best air cooling solution for Louqe's award-winning Ghost S1 enclosure. With its single 92mm fan, the new Ghost S1 Edition is tailored for use in this case and has been updated with the latest SecuFirm2™ mounting hardware for all current mainstream sockets. Topped off with our further improved NT-H2 thermal compound and a full 6-year manufacturer's warranty, the NH-L12 Ghost S1 Edition is the ideal choice for premium grade quiet builds in the Louqe Ghost S1 chassis.

Enjoy your NH-L12 Ghost S1 Edition!

Yours sincerely,  
  
Roland Mossig, Noctua CEO

This manual will guide you through the installation process of the SecuFirm2™ mounting system step by step.

Prior to installing the cooler, please consult the compatibility centre on our website ([ncc.noctua.at](http://ncc.noctua.at)) and verify that the cooler is fully compatible with your motherboard.



The NH-L12 heatsink has been designed before the introduction of LGA17xx. As the clearance specifications for LGA17xx differ from other sockets, verifying that your motherboard is fully compatible with the NH-L12 is especially crucial on this platform.

Please also make sure that your PC case offers sufficient clearance for the cooler and that there are no compatibility issues with any other components (e.g. tall RAM modules).

Double check that the heatsink and fan clips do not make contact with the VGA card, other PCIe cards, motherboard heatsinks or any other components.

Noctua cannot be held responsible for any damage or losses caused by compatibility issues.

Should you encounter any difficulties, please check the FAQs on our website ([www.noctua.at/faqs](http://www.noctua.at/faqs)) and don't hesitate to contact our support team at [support@noctua.at](mailto:support@noctua.at).

Multilingual versions of this manual are available on our website: [www.noctua.at/manuals](http://www.noctua.at/manuals)

### Required mounting parts:

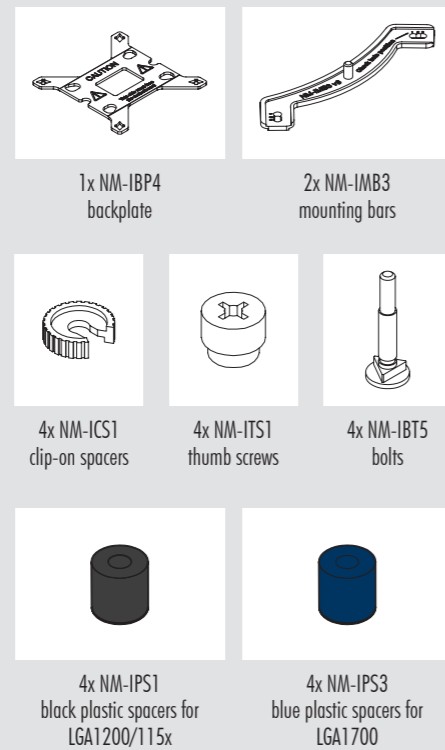

## 1 Removing the motherboard

If you would like to use the cooler on an assembled system and your case does not have a cut-out at the rear side of the motherboard tray, you must first remove the motherboard from the case in order to be able to install the supplied backplate.

## 2 Setting up the backplate

First, identify the side of the backplate that should face the motherboard (marked with caution signs). Then choose the appropriate hole spacing for your socket and insert the four bolts into the backplate from the opposite side (marked with model name, SecuFirm2™ branding and numbers for hole spacing) at the appropriate position.

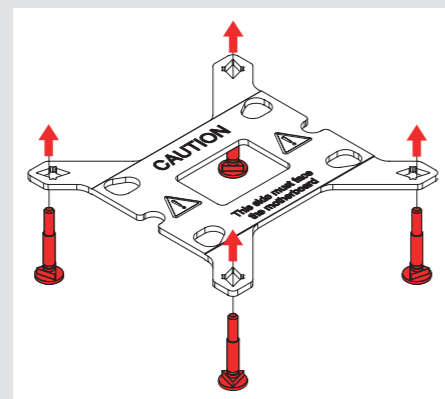

Use hole position 1 for LGA1200/115x (LGA1150, LGA1151, LGA1155, LGA1156) and hole position 2 for LGA1700 (LGA17xx family):

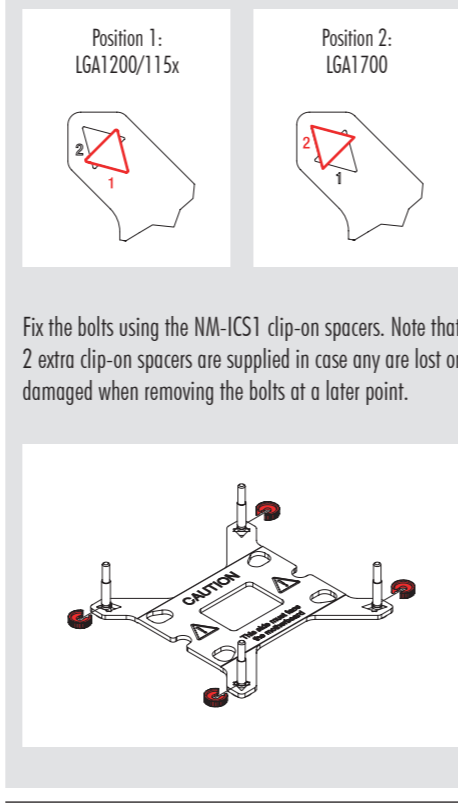

## 3 Attaching the backplate

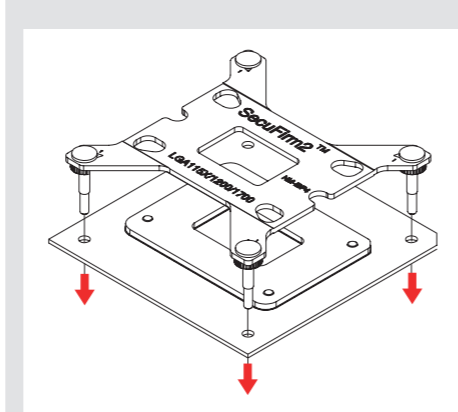

**Caution:** The supplied backplate will install over the motherboard's stock backplate, so the motherboard's stock backplate must not be taken off.

Place the backplate on the rear side of the motherboard so that the bolts protrude through the mounting holes.

## 4 Installing the mounting bars

Please first choose the correct set of plastic spacers and the correct set of holes on the mounting bars according to whether you are using an LGA1200/LGA115x (LGA1150, LGA1151, LGA1155, LGA1156) or an LGA1700 (LGA17xx family) socket motherboard.

Use the black NM-IPS1 plastic spacers for LGA1200/LGA115x (LGA1150, LGA1151, LGA1155, LGA1156) and the blue NM-IPS3 spacers for LGA1700 (LGA17xx family).

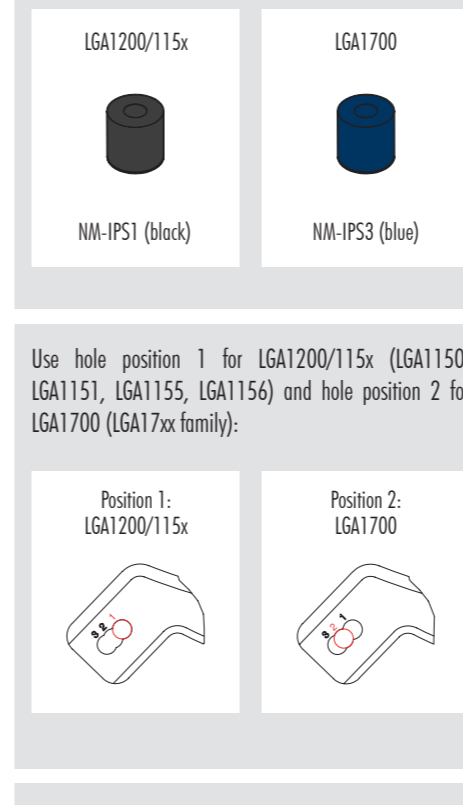

**Caution:** Make sure to use the correct hole position on both ends of the NM-IMB3 mounting bars so that they will not be misaligned.

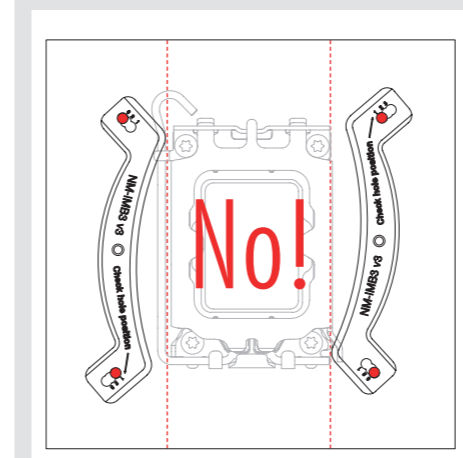

Put the plastic spacers onto the bolts of the backplate, then add the mounting bars.

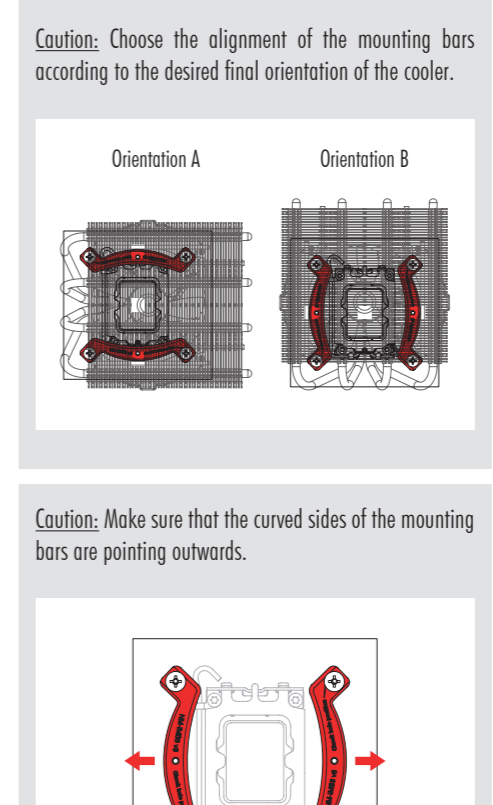
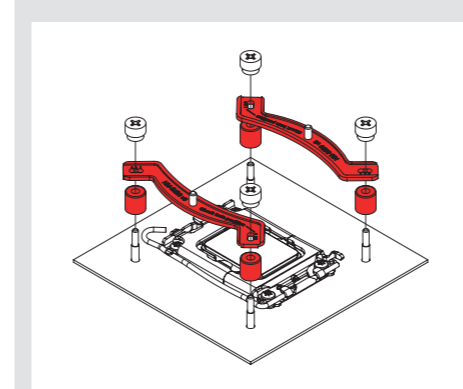

**Caution:** Make sure that the curved sides of the mounting bars are pointing outwards.

Fix the mounting bars using the four NM-ITS1 thumb screws.

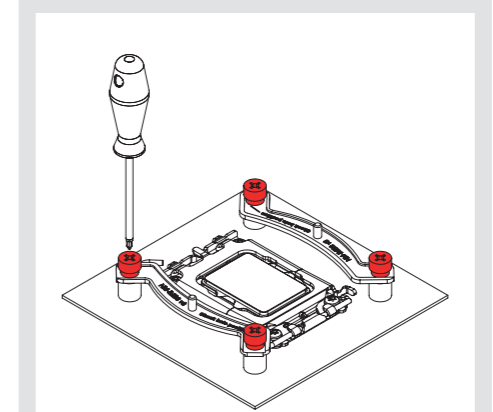

**Caution:** Gently tighten the screws until they stop, but do not use excessive force (max. torque 0.6 Nm).

## 5 Applying the thermal paste

If there are residual traces of thermal paste or thermal pads on your CPU, please clean them off first. Then apply the supplied NT-H2 thermal paste onto the CPU as shown in the following images.

For LGA1700 (LGA17xx family), apply 5 small dots; 4 dots with ~2mm diameter near the corners plus 1 dot with 3-4mm diameter in the centre:

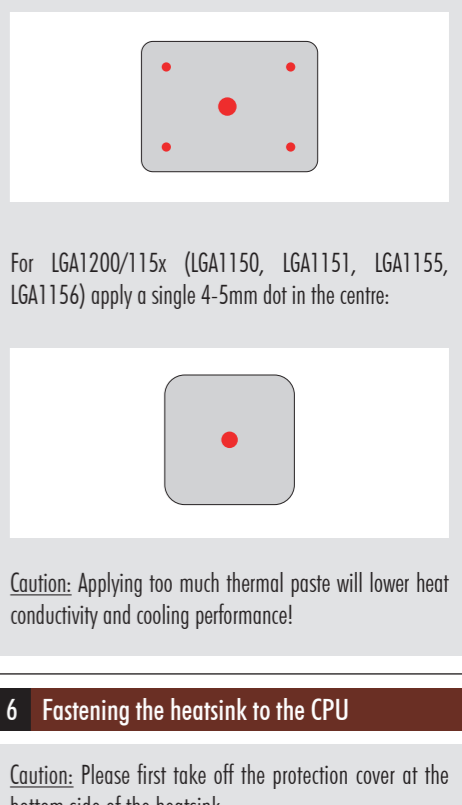

**Caution:** Applying too much thermal paste will lower heat conductivity and cooling performance!

Then put the heatsink onto the CPU and screw it to the screw threads of the mounting bars.

Perform 2-3 turns on each screw, then repeat until both are fully tightened.

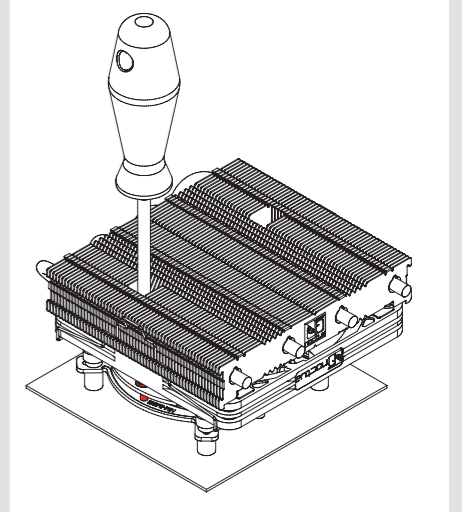

**Caution:** Gently tighten the screws until they stop, but do not use excessive force (max. torque 0.6 Nm).

Note that you can reach through the blades of the fan using the supplied screwdriver. There is thus no need to take off the fan for installation.



## 7 Fan setup

Connect the fan to the motherboard's CPU fan header.

Depending on your CPU and the temperature inside the case, you may interconnect the supplied NA-RC7 Low-Noise Adaptor (L.N.A.) in order to further reduce the fan's operating noise.

**Caution:** When using the L.N.A., check the temperature of your CPU using appropriate software (e.g. the respective applications of your motherboard manufacturer), in order to evade automatic throttling of the CPU due to the increased temperature.

If the cooling performance is insufficient, please increase case ventilation or remove the L.N.A.

## ! Transporting your system

Due to the low weight of the cooler, it is not necessary to take it off for transport.

## ! Warranty, support and FAQs

Even with high-grade products and strict quality control, the possibility of defects cannot be eliminated entirely. Therefore, we aim at providing the highest possible level of reliability and convenience by offering a warranty period of 6 years and direct, fast and straightforward RMA service.

Should you encounter any problems with your NH-L12 Ghost S1 Edition, please don't hesitate to contact our support team ([support@noctua.at](mailto:support@noctua.at)).

Please also consult the FAQ section on our website: [www.noctua.at/faqs](http://www.noctua.at/faqs)

## ! LGA20xx

Dear customer,

Congratulations on choosing the Noctua NH-L12 Ghost S1 Edition.

Our classic NH-L12 has proven to be the best air cooling solution for Louqe's award-winning Ghost S1 enclosure. With its single 92mm fan, the new Ghost S1 Edition is tailored for use in this case and has been updated with the latest SecuFirm2™ mounting hardware for all current mainstream sockets. Topped off with our further improved NT-H2 thermal compound and a full 6-year manufacturer's warranty, the NH-L12 Ghost S1 Edition is the ideal choice for premium grade quiet builds in the Louqe Ghost S1 chassis.

Enjoy your NH-L12 Ghost S1 Edition!

Yours sincerely,

Roland Mossig, Noctua CEO

This manual will guide you through the installation process of the SecuFirm2™ mounting system step by step.

Prior to installing the cooler, please consult the compatibility centre on our website ([ncc.noctua.at](http://ncc.noctua.at)) and verify that the cooler is fully compatible with your motherboard.

Please also make sure that your PC case offers sufficient clearance for the cooler and that there are no compatibility issues with any other components (e.g. tall RAM modules).

Double check that the heatsink and fan clips do not make contact with the VGA card, other PCIe cards, motherboard heatsinks or any other components.

Noctua cannot be held responsible for any damage or losses caused by compatibility issues.

Should you encounter any difficulties, please check the FAQs on our website ([www.noctua.at/faqs](http://www.noctua.at/faqs)) and don't hesitate to contact our support team at [support@noctua.at](mailto:support@noctua.at).

Multilingual versions of this manual are available on our website: [www.noctua.at/manuals](http://www.noctua.at/manuals)

## Required mounting parts:

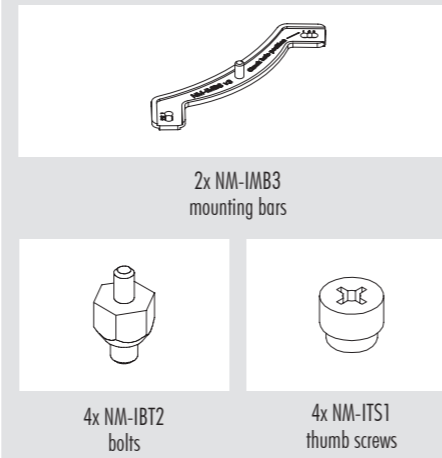

## 1 Installing the mounting bars

First screw the NM-IBT2 bolts into the screw threads of the LGA20xx socket frame.

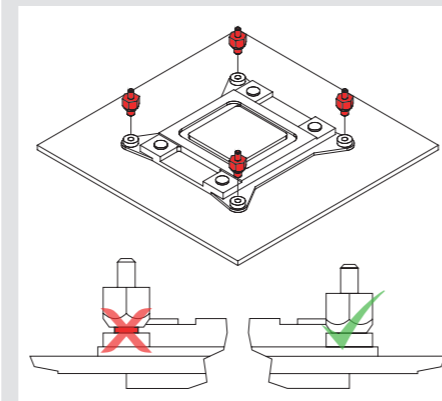

Then put the NM-IMB3 mounting bars onto the bolts.

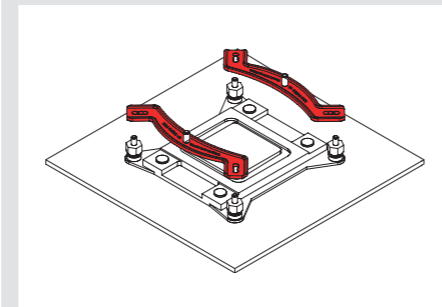

**Caution:** Choose the alignment of the mounting bars according to the desired final orientation of the cooler.

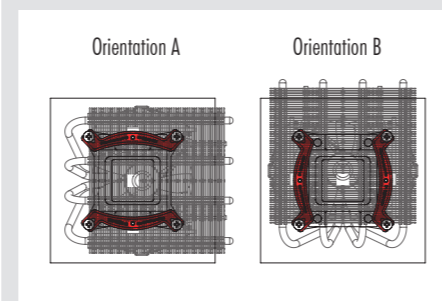

**Caution:** Make sure that the curved sides of the mounting bars are pointing outwards.

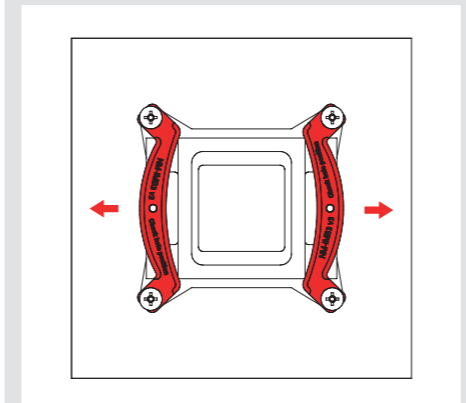

Fix the mounting bars using the four NM-ITS1 thumb screws.

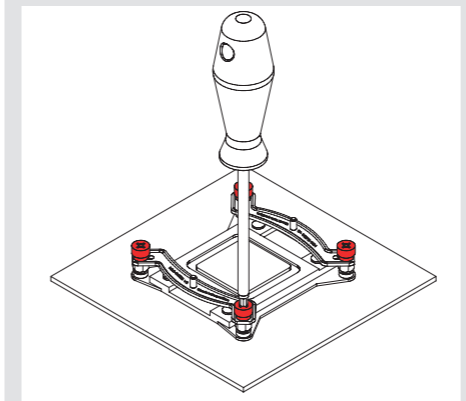

**Caution:** Gently tighten the screws until they stop, but do not use excessive force (max. torque 0.6 Nm).

## 2 Applying the thermal paste

If there are residual traces of thermal paste or thermal pads on your CPU, please clean them off first.

Then press a small drop with 4-5mm diameter of NT-H2 thermal paste onto the centre of the heat-spreader.

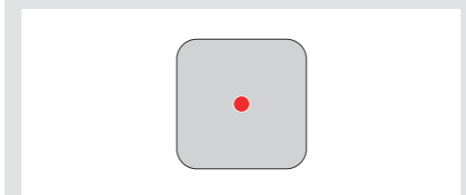

**Caution:** Applying too much thermal paste will lower heat conductivity and cooling performance!

## 3 Fastening the heatsink to the CPU

Please refer to step 6 of the LGA1700, LGA1200 & LGA115x installation manual.

## 4 Fan configuration

Please refer to step 7 of the LGA1700, LGA1200 & LGA115x installation manual.

## ! Transporting your system

Due to the low weight of the cooler, it is not necessary to take it off for transport.

## ! Warranty, support and FAQs

Even with high-grade products and strict quality control, the possibility of defects cannot be eliminated entirely. Therefore, we aim at providing the highest possible level of reliability and convenience by offering a warranty period of 6 years and direct, fast and straightforward RMA service.

Should you encounter any problems with your NH-L12 Ghost S1 Edition, please don't hesitate to contact our support team ([support@noctua.at](mailto:support@noctua.at)).

Please also consult the FAQ section on our website: [www.noctua.at/faqs](http://www.noctua.at/faqs)



## ! AMD (AM4 & AM5)

Dear customer,

Congratulations on choosing the Noctua NH-L12 Ghost S1 Edition. Our classic NH-L12 has proven to be the best air cooling solution for Louqe's award-winning Ghost S1 enclosure. With its single 92mm fan, the new Ghost S1 Edition is tailored for use in this case and has been updated with the latest SecuFirm2™ mounting hardware for all current mainstream sockets. Topped off with our further improved NT-H2 thermal compound and a full 6-year manufacturer's warranty, the NH-L12 Ghost S1 Edition is the ideal choice for premium grade quiet builds in the Louqe Ghost S1 chassis.

Enjoy your NH-L12 Ghost S1 Edition!

Yours sincerely,



Roland Mossig, Noctua CEO

This manual will guide you through the installation process of the SecuFirm2™ mounting system step by step.

Prior to installing the cooler, please consult the compatibility centre on our website ([ncc.noctua.at](http://ncc.noctua.at)) and verify that the cooler is fully compatible with your motherboard. Please also make sure that your PC case offers sufficient clearance for the cooler and that there are no compatibility issues with any other components (e.g. tall RAM modules). Double check that the heatsink and fan clips do not make contact with the VGA card, other PCIe cards, motherboard heatsinks or any other components. Noctua cannot be held responsible for any damage or losses caused by compatibility issues. Should you encounter any difficulties, please check the FAQs on our website ([www.noctua.at/faqs](http://www.noctua.at/faqs)) and don't hesitate to contact our support team at [support@noctua.at](mailto:support@noctua.at).

Multilingual versions of this manual are available on our website: [www.noctua.at/manuals](http://www.noctua.at/manuals)

### Required mounting parts:

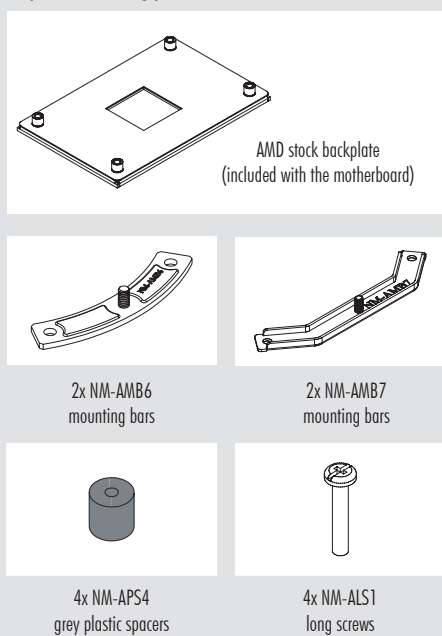

## 1 Removing the stock retention module — putting the backplate in place

If your motherboard comes with a pre-installed CPU cooler retention module, please first remove it by unscrewing it from the backplate. The SecuFirm2™ mounting system will install directly to the stock backplate, so please keep it in place.

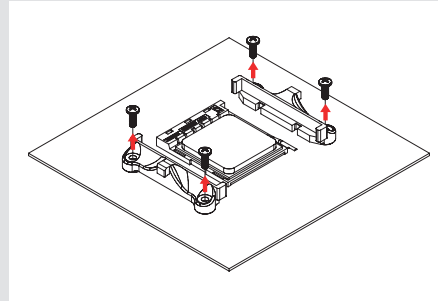

If your motherboard does not come with a pre-installed CPU cooler retention module, the AMD stock backplate should be included with the motherboard accessories.

Please put the backplate on the rear side of the motherboard so that the screw threads of the backplate stick through the mounting holes of the motherboard as shown below.

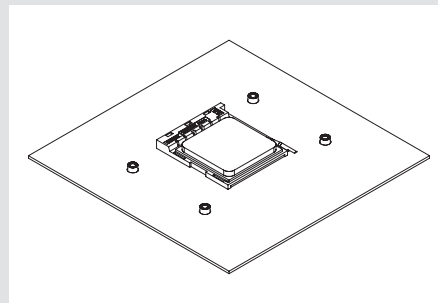

## 2 Attaching the mounting bars

**Caution:** Choose either the short NM-AMB6 or the long NM-AMB7 mounting bars according to the desired final orientation of the cooler.

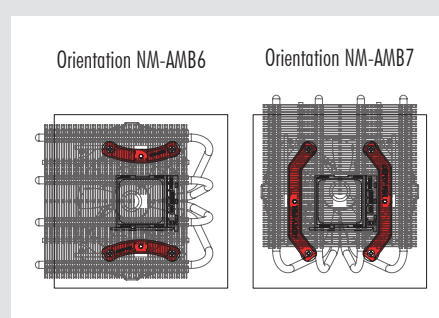

First put the plastic spacers onto the screw threads of the backplate, then fix the mounting bars using the four NM-ALS1 long screws.

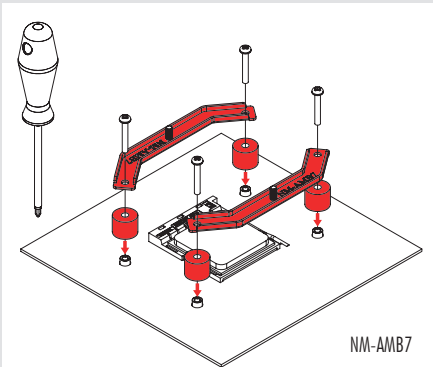
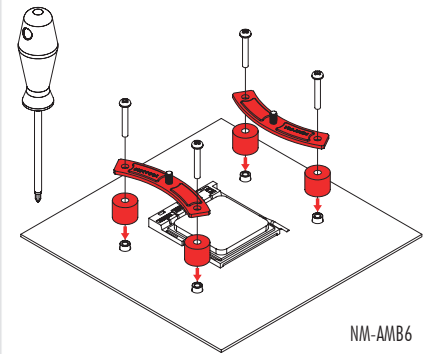

**Caution:** For the short NM-AMB6 mounting bars, make sure that the curved sides are pointing inwards.

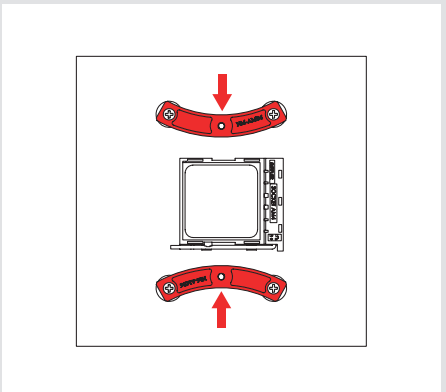

**Caution:** For the long NM-AMB7 mounting bars, make sure that the curved sides are pointing outwards.

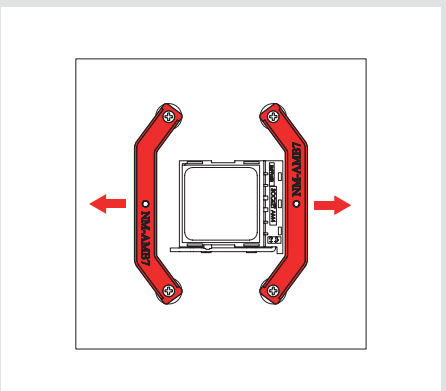

**Caution:** Gently tighten the screws until they stop, but do not use excessive force (max. torque 0.6 Nm).



### 3 Applying the thermal paste

If there are residual traces of thermal paste or thermal pads on your CPU, please clean them off first.

Apply 5 small dots; 4 small dots with ~2mm diameter near the corners plus 1 dot with 3-4mm diameter in the centre:

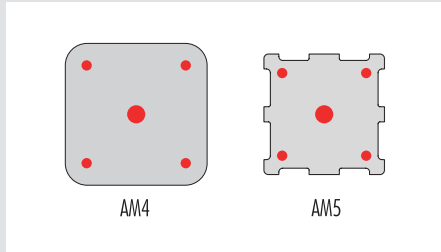

### 4 Fastening the heatsink to the CPU

**Caution:** Please first take off the protection cover at the bottom side of the heatsink.

Then put the heatsink onto the CPU and screw it to the screw threads of the mounting bars.

Perform 2-3 turns on each screw, then repeat until both are fully tightened.

Note that you can reach through the blades of the fan using the supplied screwdriver. There is thus no need to take off the fan for installation.

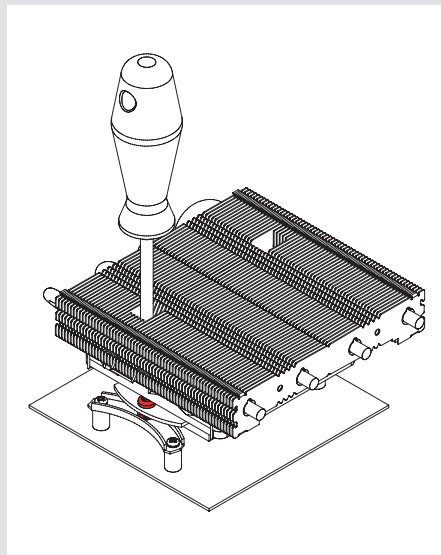

**Caution:** Gently tighten the screws until they stop, but don't use excessive force (max. torque 0.6 Nm).

### 5 Fan setup

Connect the fan to the motherboard's CPU fan header.

Depending on your CPU and the temperature inside the case, you may interconnect the supplied NA-RC7 Low-Noise Adaptor (L.N.A.) in order to further reduce the fan's operating noise.

**Caution:** When using the L.N.A., check the temperature of your CPU using appropriate software (e.g. the respective applications of your motherboard manufacturer), in order to evade automatic throttling of the CPU due to the increased temperature.

If the cooling performance is insufficient, please increase case ventilation or remove the L.N.A.

### ! Warranty, support and FAQs

Even with high-grade products and strict quality control, the possibility of defects cannot be eliminated entirely. Therefore, we aim at providing the highest possible level of reliability and convenience by offering a warranty period of 6 years and direct, fast and straightforward RMA service.

Should you encounter any problems with your NH-L12 Ghost S1 Edition, please don't hesitate to contact our support team ([support@noctua.at](mailto:support@noctua.at)).

Please also consult the FAQ section on our website: [www.noctua.at/faqs](http://www.noctua.at/faqs)